



TS 4009 | STATION TS4009, SADDLEBACK (P)

Station Diagram

North

Not to Scale

Owners Name

Address

Current Occupant

Address

**Access**

- 00 km : Intersection of S.H.1 & M.R. 264 (road to Robertson) KIMBA.
- 2.63 : Int'n. Jamberoo G Robertson 35"
- 5.76 : Int'n. Turn right.
- 7.07 : Int'n. Straight on.
- 9.25 : Jamberoo P.O.
- 9.53 : Int'n. Turn right "Albin Park"
- 10.55 : Int'n. Turn left "Miamurra Falls S"
- 11.90 : Int'n. Straight on R.H. road to Miamurra Falls.
- 15.0 : End of bitumen.
- 20.45 : Entrance to Barren Grounds Native Reserve.
- 21.39 : Picnic area. Take LH track "Griffith Trail"
- Latched gate : see Ranger.
- 24.38 : Saddleback T.S. Pillar
- 25.18 : Fork - take LH Track
- 27.94 : Leave main track. Turn left follow wheel tracks (fairly indistinct)
- 29.13 : Fox T.S. Pillar.

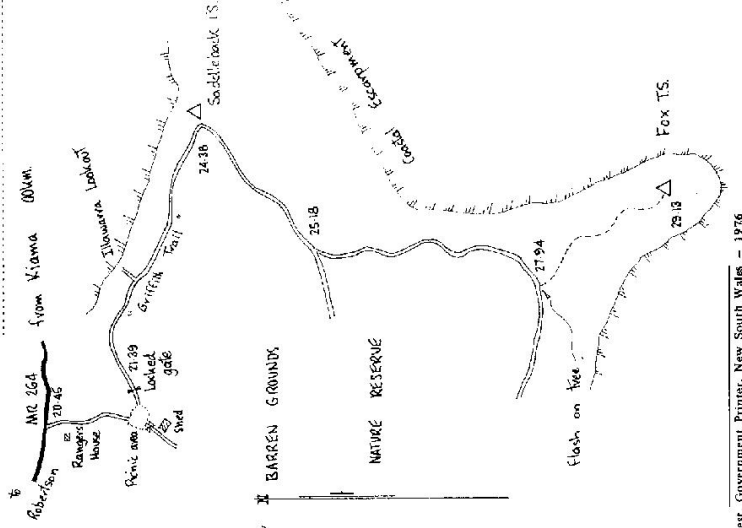

**List of Observed Directions:-**

| Standpoint: |           | Station |           |
|-------------|-----------|---------|-----------|
| Station     | Direction | Station | Direction |
|             |           |         |           |
|             |           |         |           |
|             |           |         |           |
| Standpoint: |           | Station |           |
| Station     | Direction | Station | Direction |
|             |           |         |           |
|             |           |         |           |
|             |           |         |           |

Co: CAMDEN P/O: WALLANA  
 Map Sheet: No:  
 Inspected by: C.M. STARLEY Date: 18/3/16  
 Authority: DEPT LANDS Field Book: 63195  
 Not to Scale

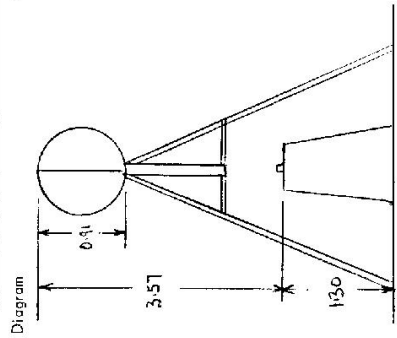

Note: Cross out word or words which do not apply

This Trig. Station has been:

1. Completely cleared to permit 360° vision to surrounding Trigs.
2. Cleared by James bearing..... from Trig. Mast
3. Trig. Mast & Vanes have been painted white & black respectively.
4. The Trig. was unpiled/~~not unpiled~~, dimensions now being:  
 Description of mark..... Concrete pillar should be explicit, e.g. Steel slug, Brass plug, Bolt, Concrete Pillar  
 Height of mark..... 1.30 m above ~~rock~~ concrete ..... 1.30 m above G.L.  
 Height of Top Vanes to Top Mast/Top pillar plate ..... 3.57 m Diameter of Vanes (vertical). (C.S.) m.  
 Height of ~~Catna~~..... m. Diameter of Catna..... m.  
 Length of Mast..... m. (approximate if not supplied)
5. A Gal. Pipe set in conc/rock has been placed/fd 3.407 m bearing 223° M from Trig. Mast/pillar
6. A Copper nail set in conc/rock has been placed/fd 1.556 m bearing 90° M from Trig. Mast/pillar
7. A..... set in conc/soil has been placed/fd..... m bearing.....° M from Trig. Mast/pillar
8. A..... set in conc/rock has been placed/fd..... m bearing.....° M from Trig. Mast/pillar
9. Connection (G) Pipe to Copper rod 4.645 m bearing 30° M
10. Connection..... to..... m bearing.....° M
11. Connection..... to..... m bearing.....° M
12. Connection..... to..... m bearing.....° M
13. Diff. Ht. Gal. Pipe is 1.54 m. ~~below~~ Pillar plate.....
14. Diff. Ht. Copper Nail is 1.48 m. ~~below~~ Pillar plate.....
15. Diff. Ht. is..... m. <sup>above</sup> ~~below~~.....
16. Diff. Ht. is..... m. <sup>above</sup> ~~below~~.....

| Date | Record of Station |
|------|-------------------|
|      |                   |
|      |                   |
|      |                   |
|      |                   |
|      |                   |

Prepared by: M. C. Kelly. Check 30/4/16 TS 4009

STATION SADDLEBACK (P) TS. 4009

Owners Name: ..... Current Occupant: .....

Address: ..... Address: .....

Access 18/3/1976  
 From Kiama take Samberoo Mountain road. At top of steep drive up mountain, and just past a small bridge, turn left into "The Barren Ground Nature Reserve". See ranger in house about 100m off road. He will give you the key to the locked gate shown on access.

- 00 Rangers house.
- 0.8 Barbeque area, take track on left signposted "Griffiths Trail".
- 0.9 locked gate.
- 1.7 Continue straight ahead. Turnoff on left signposted "Illawarra Lookout"
- All Saddleback TS.

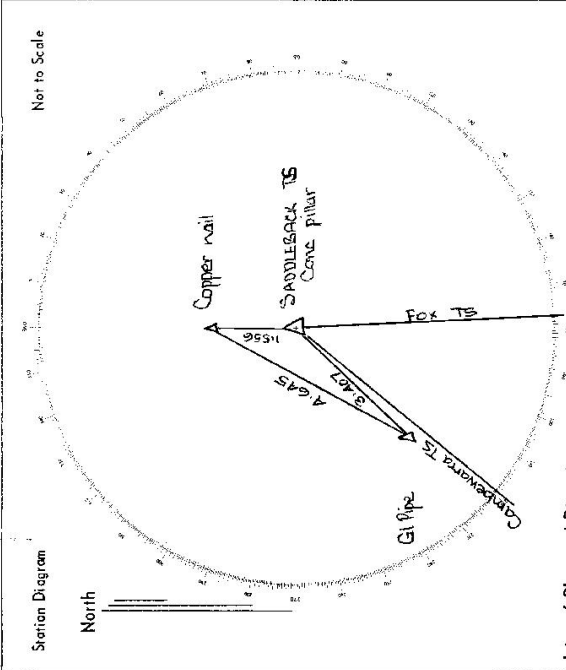

List of Observed Directions:-

| Standpoint: Pillar |               | Standpoint: Copper nail |               |
|--------------------|---------------|-------------------------|---------------|
| Station            | Direction     | Station                 | Direction     |
| FOX TS (P)         | 0° 00' 00"    | CAMBENARRA TS (P)       | 0° 00' 00"    |
| CAMBENARRA TS (P)  | 17° 54' 44.9" | SADDLEBACK TS (Pillar)  | 315° 25' 20"  |
|                    |               | GI Pipe in conc         | 346° 20' 39"  |
| Pillar             |               | Pillar                  |               |
| Station            | Direction     | Station                 | Direction     |
| FOX TS             | 0° 00' 00"    | CAMBENARRA TS (P)       | 17° 54' 49"   |
| CAMBENARRA TS (P)  | 17° 54' 49"   | GI Pipe in conc         | 17° 46' 12.5" |
| GI Pipe in conc    | 17° 46' 12.5" | Copper nail in conc     | 183° 13' 52"  |

STATION SADDLEBACK (P) TS. 4009

Owners Name: ..... Current Occupant: .....

Address: ..... Address: .....

Access 18/3/1976  
 From Kiama take Samberoo Mountain road. At top of steep drive up mountain, and just past a small bridge, turn left into "The Barren Ground Nature Reserve". See ranger in house about 100m off road. He will give you the key to the locked gate shown on access.

- 00 Rangers house.
- 0.8 Barbeque area, take track on left signposted "Griffiths Trail".
- 0.9 locked gate.
- 1.7 Continue straight ahead. Turnoff on left signposted "Illawarra Lookout"
- All Saddleback TS.

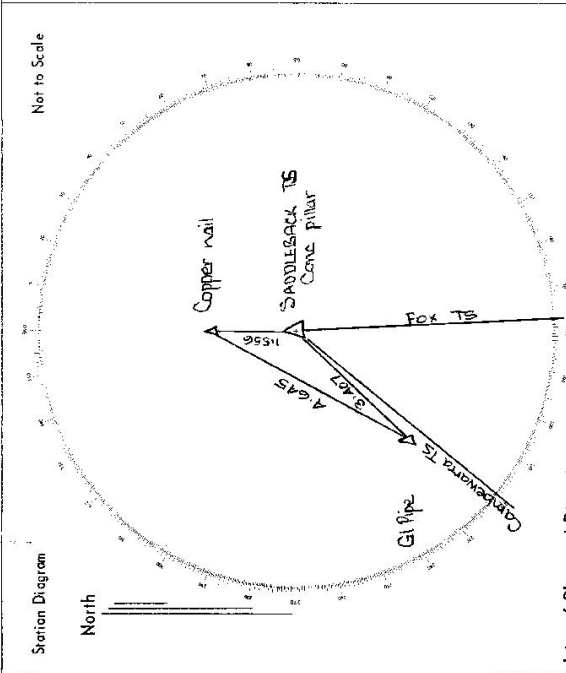

List of Observed Directions:-

| Standpoint: Pillar |               | Standpoint: Copper nail |               |
|--------------------|---------------|-------------------------|---------------|
| Station            | Direction     | Station                 | Direction     |
| FOX TS (P)         | 0° 00' 00"    | CAMBENARRA TS (P)       | 0° 00' 00"    |
| CAMBENARRA TS (P)  | 17° 54' 44.9" | SADDLEBACK TS (Pillar)  | 315° 25' 20"  |
|                    |               | GI Pipe in conc         | 346° 20' 39"  |
| Pillar             |               | Pillar                  |               |
| Station            | Direction     | Station                 | Direction     |
| FOX TS             | 0° 00' 00"    | CAMBENARRA TS (P)       | 17° 54' 49"   |
| CAMBENARRA TS (P)  | 17° 54' 49"   | GI Pipe in conc         | 17° 46' 12.5" |
| GI Pipe in conc    | 17° 46' 12.5" | Copper nail in conc     | 183° 13' 52"  |

GEODETTIC SURVEY OF N.S.W.

CENTRAL MAPPING AUTHORITY

GEODETTIC STATION RECONNAISSANCE and MAINTENANCE REPORT

Description: *360°* Note: Cross out word or words which do not apply

1. Cleared by lances bearing.....*360°*.....from Trig. Mast
2. Mast & Vanes have been painted white & black respectively.
3. The station/pillar ~~was replaced with a steel plate~~.....*19*..... dimensions now being:  
Description of marks ~~is as follows~~ *Steel Plate* should be explicit, e.g., S/Steel Pillar Plate, Steel plug, Brass plug, Bolt, G.I. Pipe  
Height of mark.....*1.566*.....m. above rock/concrete; Mark is.....*19*.....m. above G.L.  
Height of Top Vanes to ~~Top of Plate~~ *Steel Plate*.....*3.566*.....m. Diameter of Vanes (vertical).....*0.22*.....m.  
Height of Cairn.....m. Diameter of Cairn.....m. Name Plate found ~~not found~~ *found*.  
Length of Mast.....m. (approximate if not uplied)
4. A.....*C.A. Nail*.....set in conc/rock has been ~~placed~~ *found*, bearing.....*2*.....° M from ~~Mast/Plug~~ *Pillar*
5. A.....*C.A. Pipe*.....set in conc/rock has been placed ~~found~~ *found*, bearing.....*224*.....° M from ~~Mast/Plug~~ *Pillar*
6. A.....~~set in conc/rock has been placed~~ *found*, bearing.....° M from Mast/Plug/Pillar
7. A.....~~set in conc/rock has been placed~~ *found*, bearing.....° M from Mast/Plug/Pillar
8. Action required:.....*Nil Action*.....

STANDPOINT:

| Mark                 | Direction  | Horiz. Distance | Height Difference | Mark | Direction | Horiz. Distance | Height Difference |
|----------------------|------------|-----------------|-------------------|------|-----------|-----------------|-------------------|
| <i>Previous</i>      |            |                 | above standpt.    |      |           |                 | above standpt.    |
| <i>Waggon hill</i>   | <i>5°</i>  | <i>28.5</i>     | below             |      |           |                 | below standpt.    |
| <i>Willowra</i>      | <i>37</i>  | <i>26.7</i>     | above             |      |           |                 | above standpt.    |
| <i>Fox</i>           | <i>188</i> | <i>3.5</i>      | below             |      |           |                 | below standpt.    |
| <i>Cambewarra</i>    | <i>236</i> | <i>22.6</i>     | above             |      |           |                 | above standpt.    |
| <i>Wingecarribee</i> | <i>309</i> | <i>20.5</i>     | below             |      |           |                 | below standpt.    |
|                      |            |                 | above standpt.    |      |           |                 | above standpt.    |
|                      |            |                 | below             |      |           |                 | below             |

Prepared by: *J. Fanning*

Checked:

Noted on U.T.M. Card

Checked

SI 2733-1

STATION: *SADDLEBACK* No.: *4009*  
 MAP SHEET SCALE 1:250 000 *WOOLONGONG*  
 INSPECTED BY: *J. FANNING* DATE: *12th Jan 81*  
 AUTHORITY: *C.M.A.* FIELD BOOK: *1724*

Station Diagram  
 North  
 Not to Scale

08

SR 2733--2 D. West, Government Printer

|   |  |
|---|--|
| <p>STATION <b>SADDLEBACK</b> TS <b>4009</b></p> <p>Owner's Name: <i>National Parks</i></p> <p>F Address: <i>Red Saddle</i></p> <p>Phone: <i>(044) 26919</i></p> <p>Current Occupant: <i>TS 4009 in Barron Sound Nature Reserve</i></p> <p>Address: <i>Key to Locke Gate</i></p> <p>Phone: <i>(048) 872270 (after 166)</i></p> | <p><b>ACCESS</b></p> <p>Access Report of 12/1/19 was found suitable/unsuitable.</p> <p><i>From Kinna take the Jamberso Mountain Road. At top of steep drive up mountain just past small bridge TURN LEFT signpost "Barron Sound Nature Reserve". Go along gravel road.</i></p> <p><i>Unused house on right of picnic area turn head left in picnic area to locked gate (possible to drive around gate)</i></p> <p><i>Per turnoff on left to "Ilawarra Lookout"</i></p> <p><i>Saddle back T.S.</i></p> <p><b>2WD IN DRY WEATHER</b></p> |
|---|--|

| Beacon Diagram | Not to Scale |
|----------------|--------------|
|                |              |

This section to be completed by officer constructing pillar.

Original station mark found/not found.

Description of mark: .....

Original beacon found/not found.

Description of beacon: .....

Height Top of Vanes to Top Mark.....m.

Height of mark.....m. above G.L. below

Diameter of Vanes.....m. Height of Cairn.....m.

Original Beacon has/not been destroyed by me.

| Date | Record of Station |
|------|-------------------|
|      |                   |
|      |                   |
|      |                   |
|      |                   |

SI 3735-2 D. West: Government Printer

Beacon Diagram

Not to Scale

|  |                               |                          |   |
|--|-------------------------------|--------------------------|---|
| Owner's Name: <b>WARRONE PAKES</b>                   | Address: <b>FITZROY FALLS</b> | Phone: <b>888 778 44</b> | Access Report of: <b>13/1/81</b> *<br><small>* was found suitable/unsuitable.</small> |
| Current Occupant: _____                              | Address: _____                | Phone: _____             | ACCESS _____  |
| Address: <b>RANGER FOR BARKEN CROOKS NATURE RES.</b> |                               |                          |   |
| Phone: <b>IAN SACKLETT 488 772 66</b>                |                               |                          |   |
| Address: <b>5/6 FITZROY FALLS</b>                    |                               |                          |   |

This section to be completed by officer constructing pillar.

Original station mark found/not found. \_\_\_\_\_

Description of mark: .....

Original beacon found/not found. \_\_\_\_\_

Description of beacon: .....

Height Top of Vanes to Top Mark: ....., m.

Height of mark: ....., m. above rock/conc. ....., m. above G.L. below

Diameter of Vanes: ....., m. above Height of Cairn ....., m. below

Original Beacon has/has not been destroyed by me. \_\_\_\_\_

STATION **SADDLEBACK (P) 4009**

Owner's Name: **WARRONE PAKES**

Address: **FITZROY FALLS**

Phone: **888 778 44**

Access Report of: **13/1/81** \*  
\* was found suitable/unsuitable.

Current Occupant: \_\_\_\_\_

Address: \_\_\_\_\_

Phone: \_\_\_\_\_

ACCESS \_\_\_\_\_

\* From Kinna take the Tamblers Mountain Road. At top of steep drive up mountain just past small bridge turn LEFT beyond "Barren Summit Native Reserve". Go along gravel road.

8.0 Moved house on right of fence area turn left 1/4 - Pine Area to locked gate

0.8

1.7 Ret turnoff on left to "Illawarra Lookout"

4.1 Saddle back to S

2WD in DRY WEATHER

11

INSPECTED BY: **G. FORD** DATE: **3-6-2000**

Date \_\_\_\_\_

Record of Station

Cleared by lanes bearing: **CLEARER TO 15° SEANTON FOR C.A.S.** from Trig. Mast

Mast & Vanes have been painted white & black respectively. ✓